

Machining Technology II

Module MMT-13 (Master of Science in Manufacturing Technology) – Summer semester

The **lecture** includes the teaching of

... characteristics of **cutting machine tools**,

... relevant **operating equipment** as well as

... the presentation of complex **application examples**.

This qualifies the students to select suitable machine tools according to the requirements and applications in their later working life.

In the **practical exercise**, the acquired knowledge is applied in group work to the planning of a production system, taking into account various machining processes and strategies, machine tools and peripheral equipment as well as tool selection and quality control. The results are **submitted in writing** and **presented orally**.



Prof. Dr.-Ing. Prof. h.c. Dirk Biermann

Lecturer and head of institute



Timo Platt M.Sc.

Lecture and exercise supervisor

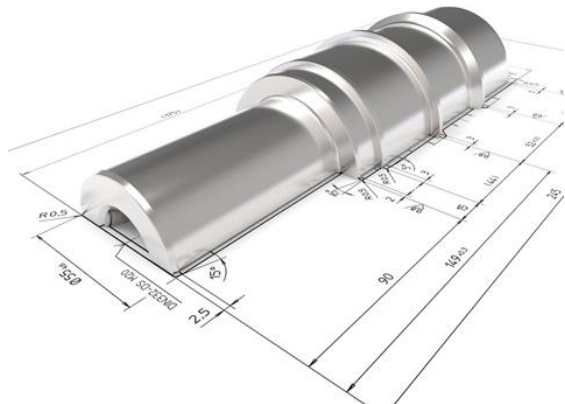

Fig. Drawing of an exemplary turned part.

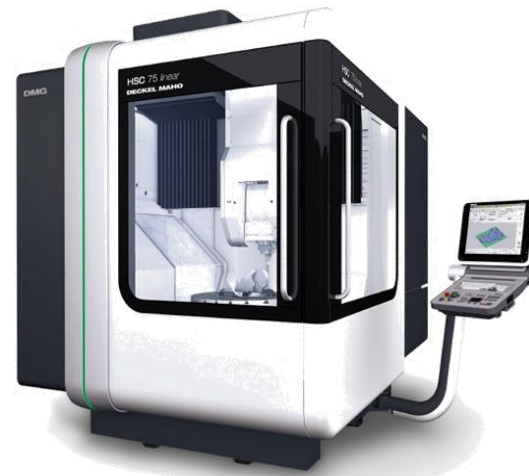

Fig. Milling center for 5-axis simultaneous machining [\[ISF\]](#).



Fig. Milling process for machining of Die-Casting Mold Inserts [\[ISF\]](#).